

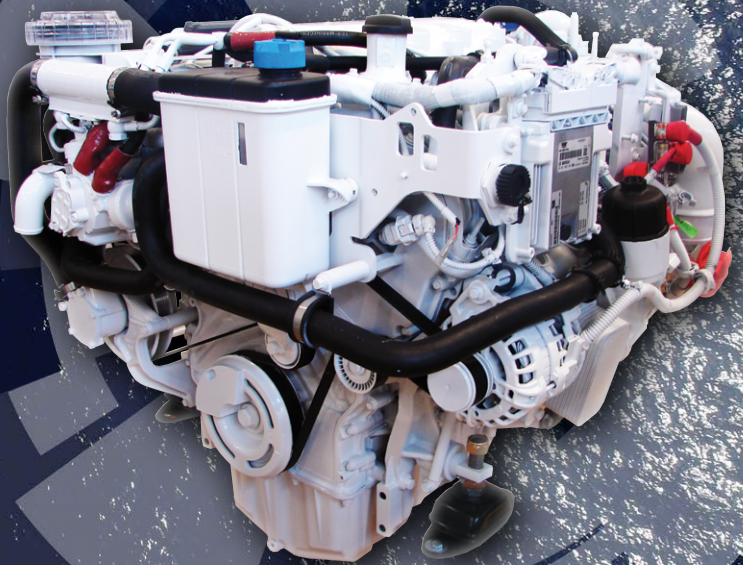

# MR 506 SH3 270



## Characteristics

The new **MR506 SH3** engine delivers exceptional performance using state-of-the-art injection technologies and turbocharging. The new 3.0L V6 engine with a power of 270 HP and a torque of 587Nm at 2200 RPM is at the top of its category. Thanks to its compactness it offers great installation flexibility.

The main technical features are the 2000 bar injection system, a double chain driven overhead camshaft and 4 valves per cylinder. Thanks to the new variable geometry VGT turbocharger with ball bearings and a water cooled turbine, the engine is able to develop both a very high specific power and an immediate response from low revolutions. Reliable, fast, ecological and with low noise levels, the new V6 diesel engine of the MR506 family is able to meet the needs of every yachtsman.

## Engine Specification

<b>Engine model</b>	<b>MR 506 SH3</b>
<b>Max. Power</b>	<b>270 HP - 4000 rpm</b>
<b>Displacement</b>	<b>3.0 L</b>
<b>Bore and Stroke</b>	<b>83 x 92 mm</b>
<b>Cylinders</b>	<b>V6 (60 degree angle)</b>
<b>Air charging system</b>	<b>Variable geometry turbocharger (Water Cooled turbine housing)</b>
<b>Drivetrain</b>	<b>Chain-driven DOHC</b>
<b>Fuel injection system</b>	<b>Common Rail 2.000 bar</b>
<b>Emissions</b>	<b>EPA TIER3 / RCD2 / IMO / BSO2 / CCS</b>

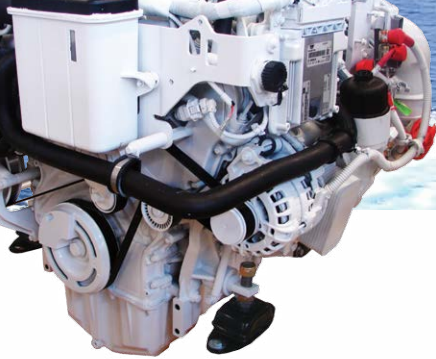

# MR506

## SH3 270

### Rated max power output

MR 506 SH3	
Maximum power	270 HP / 4000 rpm
Maximum torque	587 Nm / 2200 rpm

### Standard Equipment

- Flywheel and fly wheel housing
- 12V electric starter, Hot stud and ground stud
- 12V-110A battery charging alternator
- Oil and fuel filters
- Air filter
- Engine cooling system w/ single seawater heat exchanger
- Lubricating engine oil by engine coolant heat exchanger
- Cooled exhaust gas manifolds
- Air charging system with single variable geometry turbocharger (VGT) and Water Cooled turbine housing
- Low pressure fuel pump integrated on the high pressure injection pump
- Sea water circulating pump
- Engine mounted sea water filter
- Centrifugal pump for engine coolant circulation
- Coolant expansion tank
- Engine shock absorbers
- White painting finish

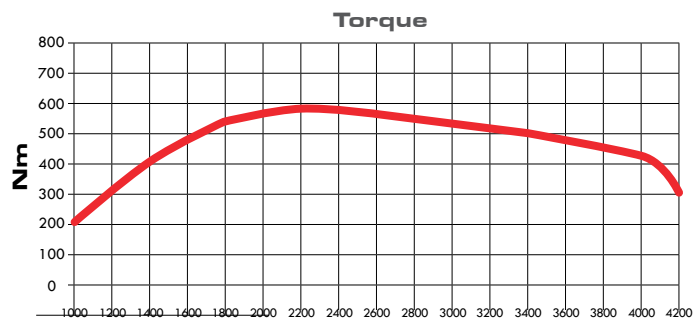
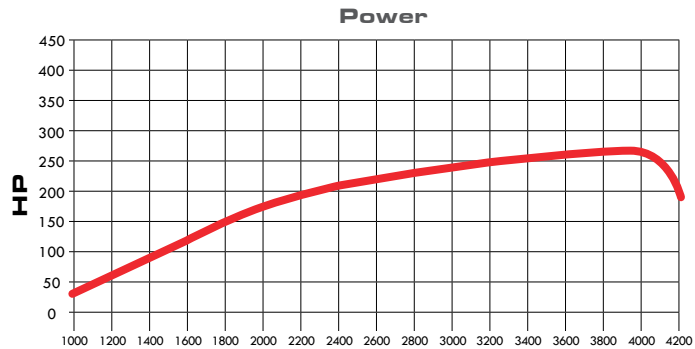

### Dimensional Drawing

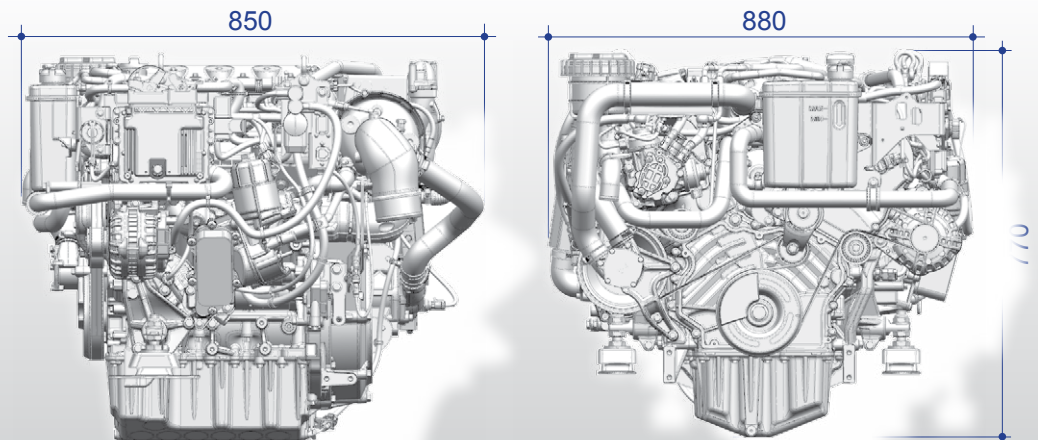

Dimension and weight	
Length	850 mm
Width	880 mm
Height	770 mm
Weight	365 Kg

Engine types and characteristics may be subject to modification without prior notice.

